

Information for the installer

# LST Style 3

Floor mounted - suitable with horizontal Precision emitters

Item no.	Parts included	Qty
1	Front Panel	1
2	Endboxes	2
3	Horizontal Top Grille	1
4	Bracket Kit (Grille)	1

**Important Notes:**

- Fixings for LST assembly are included in the Bracket Kit (item 4). Content will vary depending on the length of the LST.
- Fixings to install LST to the wall are not included.
- Emitter and fixings shown on exploded view. Installation instructions provided with emitter.

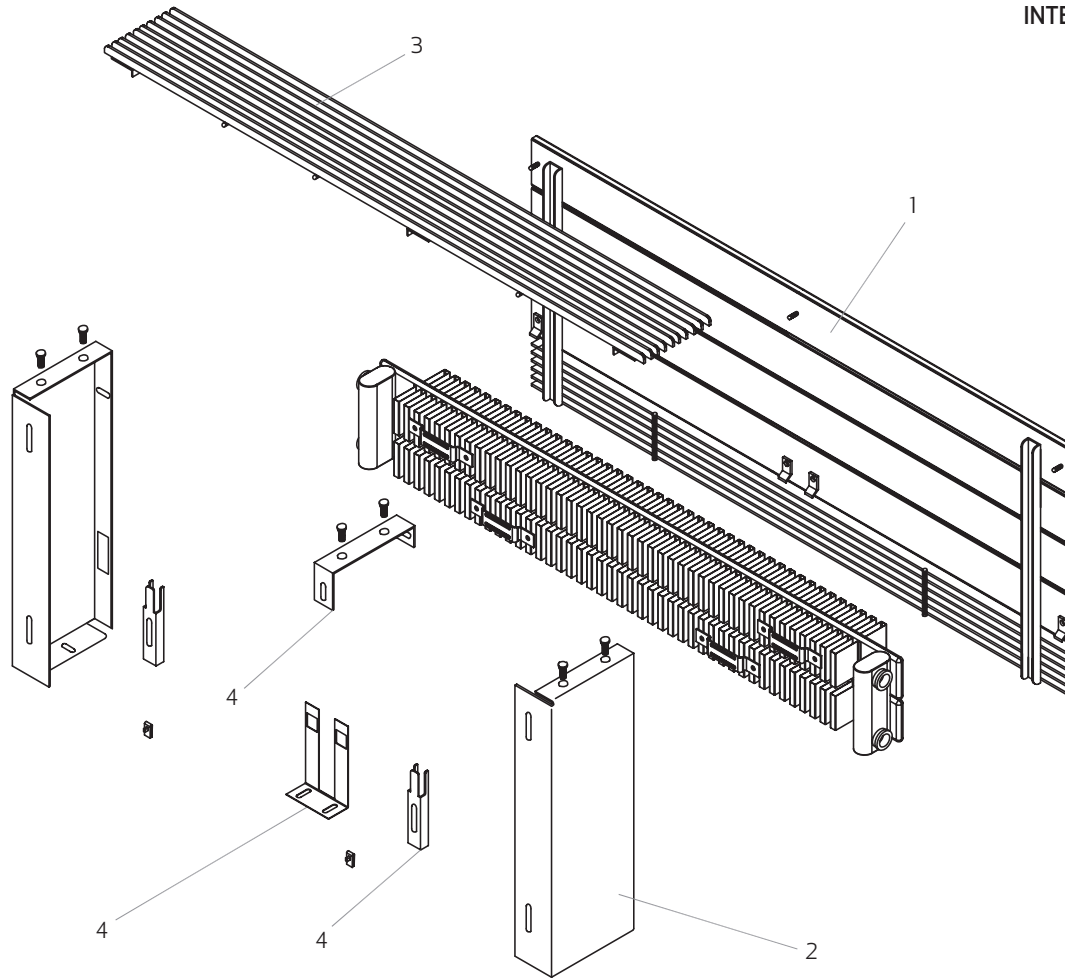

INTERMEDIATE BRACKET PANEL DEPTH & BRACKET TYPE

PANEL LENGTH (mm)	TOP BRACKET SUPPORT	BOTTOM SUPPORT	DIST. A	DIST. B	FIG NO.
	G10, G15, G17, G25	F10			
0-1000	0	0			
1001-1550	1	1	609	0	1
1501-2150	1	1	909	0	1
2151-2750	1	1	1209	0	1
2751-3000	2	2	909	1809	2

FIG. 1

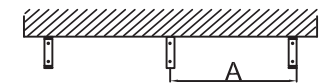
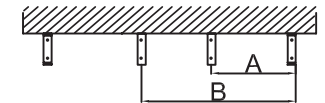

FIG. 2



All dimensions are in mm.

**Merriott UK & Ireland**  
 Purmo Group (UK) Ltd,  
 Eastern Avenue,  
 Team Valley, Gateshead,  
 Tyne & Wear, NE11 0PG  
 Tel: 0330 0415 472

sales@merriottuk.com  
 sales@merriott.ie

www.merriottuk.com / www.merriott.ie  
 Follow us on @merriottuk and

**EMITTER/LST CASE POSITIONING**

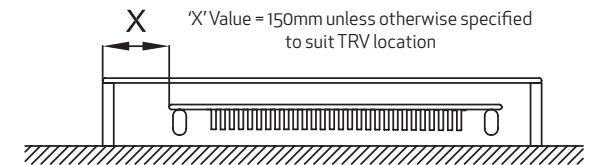
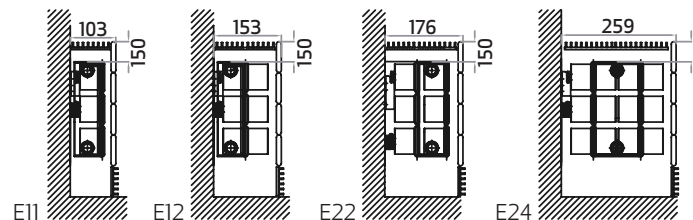

## Information for the installer

# LST Style 3

Floor mounted - suitable with horizontal Precision emitters

## Installation Procedure:

1. For TRV cutout positions and LST locations to suit, contact the Merriott sales office.
2. Fix endboxes to wall surface as shown in FIG.1 ensuring that required dimensions are adhered to. The centre of the bottom bracket corresponds to the centre of the intermediate tabs on the front panel.
3. If required fit immediate foot to the ground (see FIG. 2).
4. Locate tabs on inside of front panel. Slide into slots provided in endboxes. Push the panel into its upright position and lock into place using M8 nuts and washers (see FIG. 3).
5. Place top grille in position as shown in FIG. 4. Lock in place by inserting M4 hex socket screws through the keyhole plates in the grille and into the threaded hole in the endbox.

FIG.1

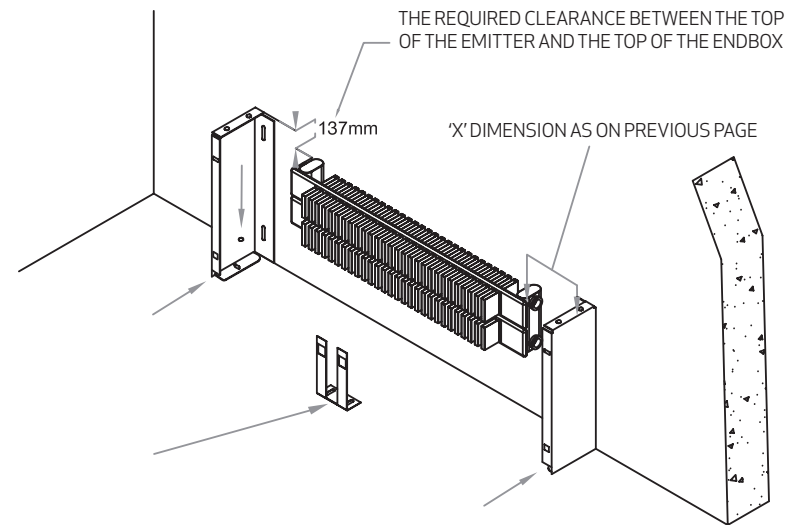

FIG.2

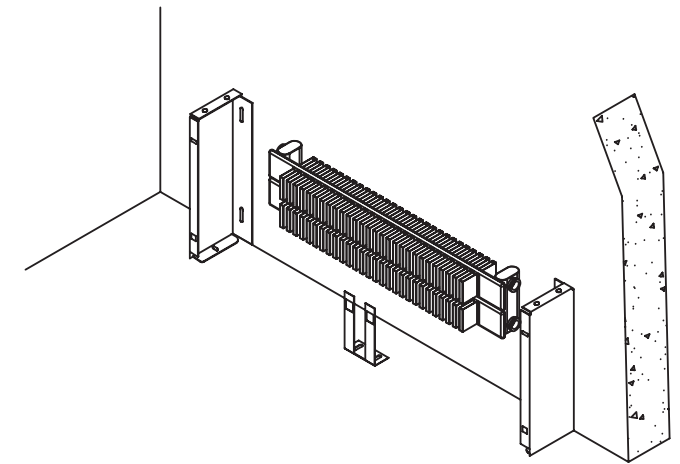

FIG.3

Emitter Height	Case Height
143mm	350mm
215mm	420mm
288mm	490mm
360mm	560mm
433mm	630mm
505mm	700mm
578mm	770mm
650mm	840mm
723mm	910mm
795mm	980mm

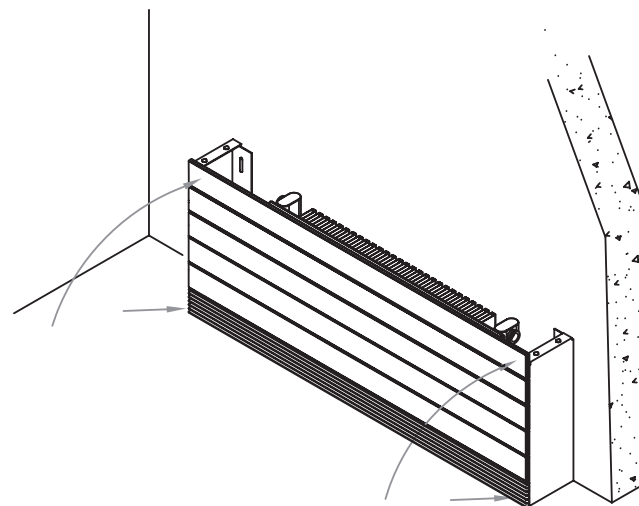
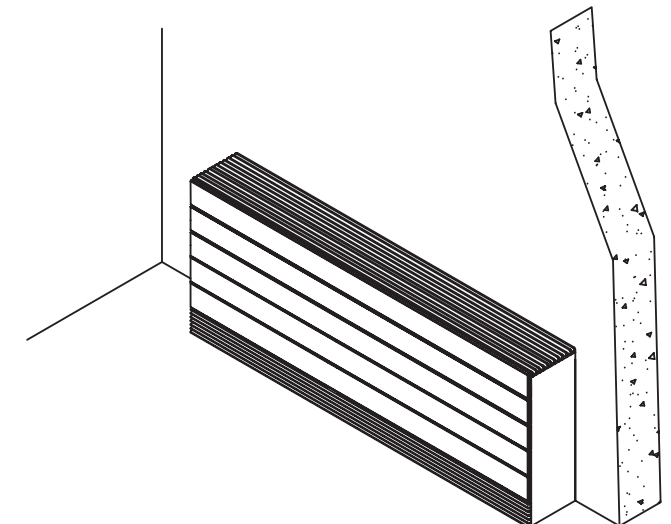

FIG.4



Information for the installer

# LST Style 4

Floor mounted - suitable with horizontal Precision emitters

Item no.	Parts included	Qty
1	Front Panel	1
2	Endboxes	2
3	Horizontal Top Grille	1
4	Bracket Kit (Grille)	1

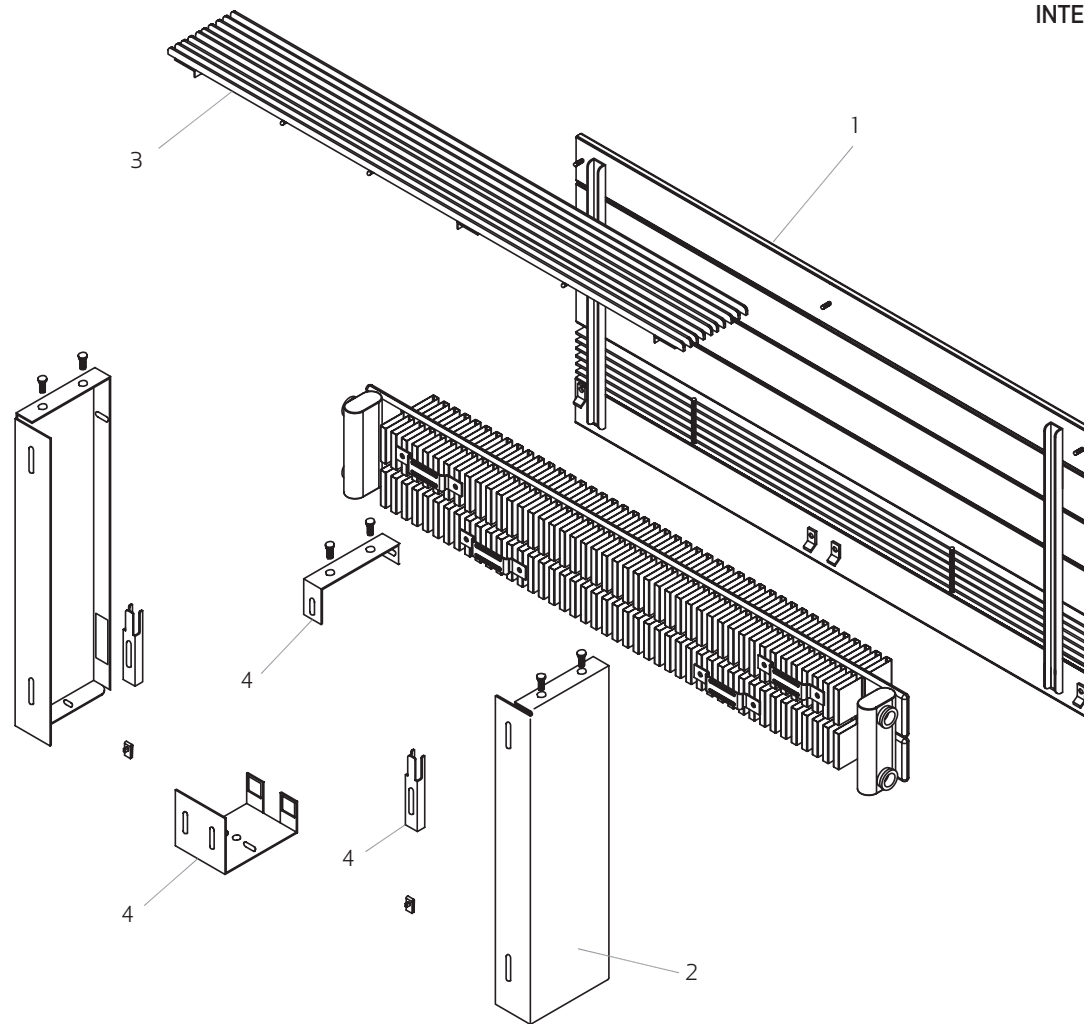

INTERMEDIATE BRACKET PANEL DEPTH & BRACKET TYPE

PANEL LENGTH (mm)	TOP BRACKET SUPPORT	BOTTOM SUPPORT	DIST. A	DIST. B	FIG NO.
	<b>G10, G15, G17, G25</b>	<b>B10, B15, B17, B25</b>			
0-1000	0	0			
1001-1550	1	1	609	0	1
1501-2150	1	1	909	0	1
2151-2750	1	1	1209	0	1
2751-3000	2	2	909	1809	2

**Important Notes:**

- Fixings for LST assembly are included in the Bracket Kit (item 4). Content will vary depending on the length of the LST.
- Fixings to install LST to the wall are not included.
- Emitter and fixings shown on exploded view. Installation instructions provided with emitter.

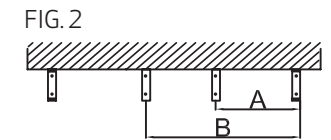
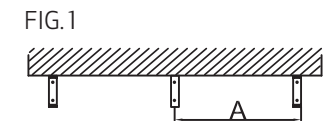

All dimensions are in mm.

**Merriott UK & Ireland**  
 Purmo Group (UK) Ltd,  
 Eastern Avenue,  
 Team Valley, Gateshead,  
 Tyne & Wear, NE11 0PG  
 Tel: 0330 0415 472

sales@merriottuk.com  
 sales@merriott.ie

www.merriottuk.com / www.merriott.ie  
 Follow us on @merriottuk and

**EMITTER/LST CASE POSITIONING**

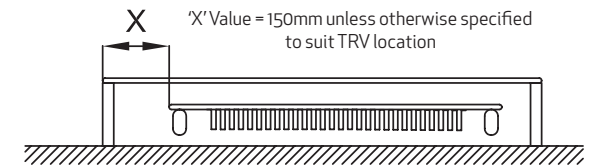
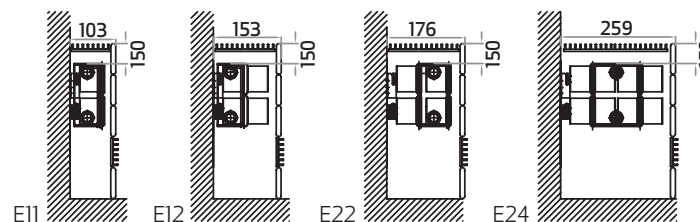

# LST Style 4

Floor mounted - suitable with horizontal Precision emitters

## Installation Procedure:

1. For TRV cutout positions and LST locations to suit, contact the Merriott sales office.
2. Fix endboxes to wall surface as shown in FIG.1 ensuring that required dimensions are adhered to. The centre of the bottom bracket corresponds to the centre of the intermediate tabs on the front panel. The bottom of the bracket should be in line with the bottom of the endboxes.
3. If required fit intermediate foot to the ground (see FIG. 2).
4. Locate tabs on inside of front panel. Slide into slots provided in endboxes. Push the panel into its upright position and lock in place using M8 nuts and washers (see FIG. 3).
5. Take top grille and place in position as shown in FIG.4. Lock in place by inserting M4 hex socket screws through the keyhole plates in the grille and into the threaded hole in the endbox.

FIG.1

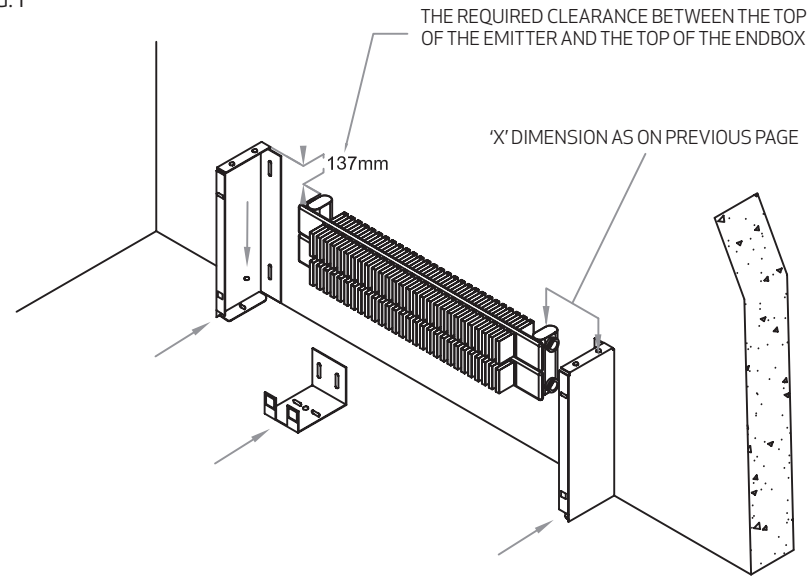

FIG.2

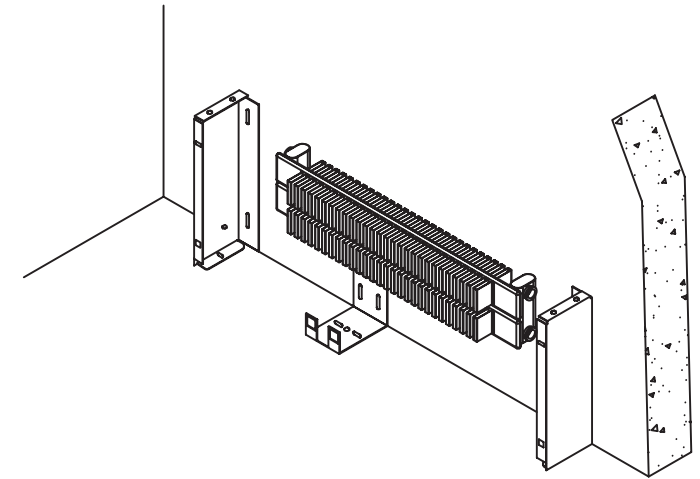
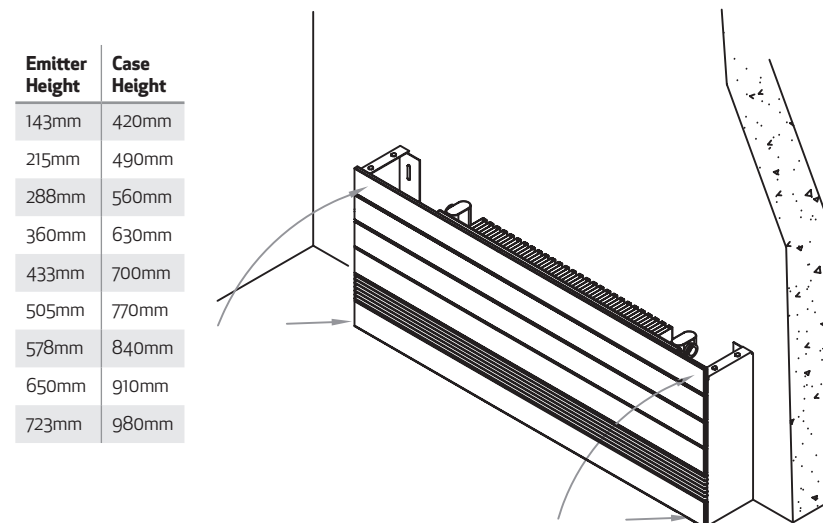
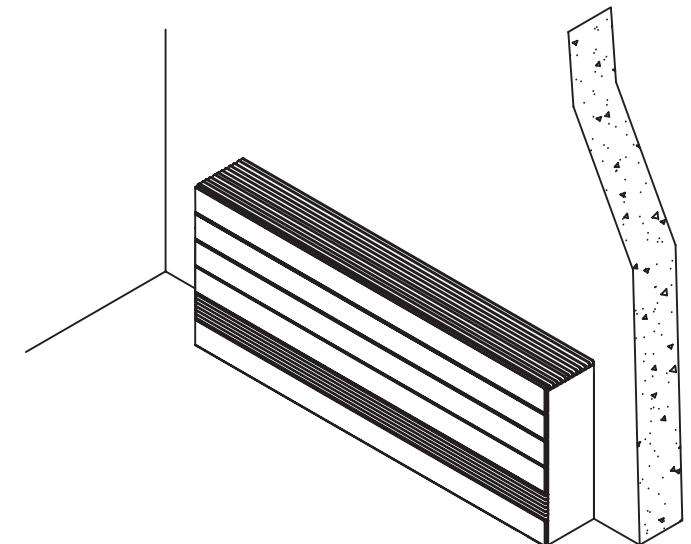

FIG.3



Emitter Height	Case Height
143mm	420mm
215mm	490mm
288mm	560mm
360mm	630mm
433mm	700mm
505mm	770mm
578mm	840mm
650mm	910mm
723mm	980mm

FIG.4



Information for the installer

# LST Style 8

Floor mounted - suitable with horizontal Precision emitters

Item no.	Parts included	Qty
1	Front Panel	1
2	Endboxes	2
3	Solid Top	1
4	Horizontal Front Grille	1
5	Bracket Kit (Solid Top)	1

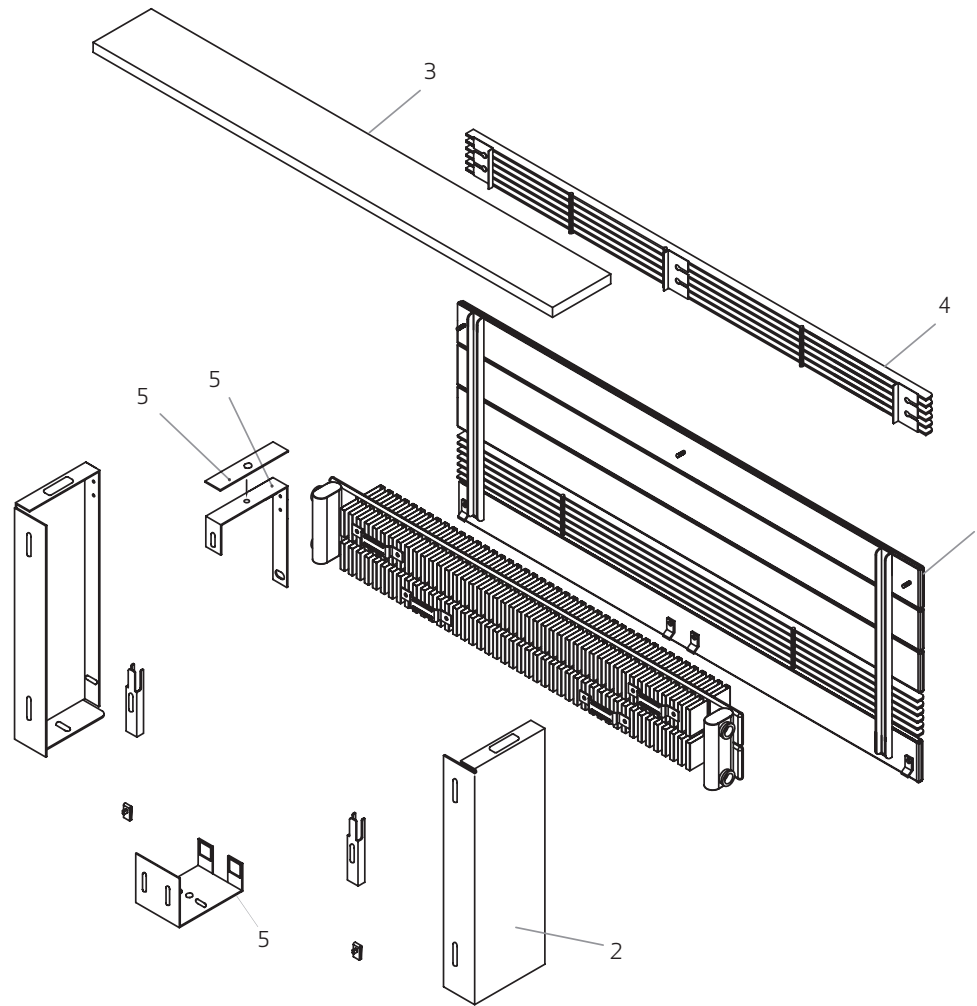

INTERMEDIATE BRACKET PANEL DEPTH & BRACKET TYPE

PANEL LENGTH (mm)	BOTTOM SUPPORT	SOLID TOP SUPPORT	FIXING SUPPORT	DIST. A	DIST. B	FIG NO.
	<b>B10, B15, B17, B25</b>	<b>S10, S15, S17, S25</b>	<b>ST0, ST5, ST7, ST9</b>			
0-1000	0	0	0			
1001-1550	1	1	1	609	0	1
1501-2150	1	1	1	909	0	1
2151-2750	1	1	1	1209	0	1
2751-3000	2	2	2	909	1809	2

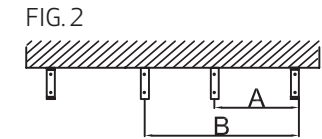
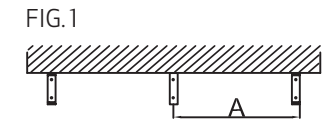

**Important Notes:**

- Fixings for LST assembly are included in the Bracket Kit (item 5). Content will vary depending on the length of the LST.
- Fixings to install LST to the wall are not included.
- Emitter and fixings shown on exploded view. Installation instructions provided with emitter.

All dimensions are in mm.

**Merriott UK & Ireland**  
 Purmo Group (UK) Ltd,  
 Eastern Avenue,  
 Team Valley, Gateshead,  
 Tyne & Wear, NE11 0PG  
 Tel: 0330 0415 472

sales@merriottuk.com  
 sales@merriott.ie

www.merriottuk.com / www.merriott.ie  
 Follow us on @merriottuk and

**EMITTER/LST CASE POSITIONING**

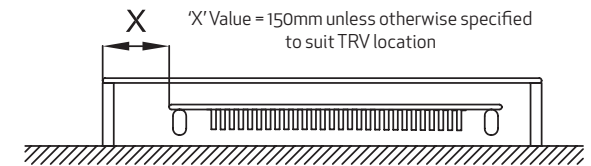
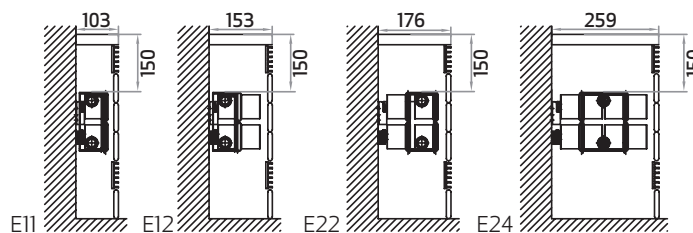

## Information for the installer

# LST Style 8

Floor mounted - suitable with horizontal Precision emitters

## Installation Procedure:

1. For TRV cutout positions and LST locations to suit, contact the Merriott sales office.
2. Fix endboxes to wall surface as shown in FIG.1 ensuring that required dimensions are adhered to.

The centre of the bottom bracket corresponds to the centre of the intermediate tabs on the front panel. The bottom of the bracket should be in line with the bottom of the endboxes.

3. Locate tabs on inside of front panel. Slide into slots provided in endboxes. Push the panel into its upright position and lock in place using M8 nuts and washers provided (see FIG. 3).
4. Fix solid top onto top of endbox with bolts provided.
5. Place front top grille in position as shown in FIG. 4. Lock in place by inserting M4 hex socket screws through the keyhole plates in the grille and into the threaded hole in the endbox.

FIG.1

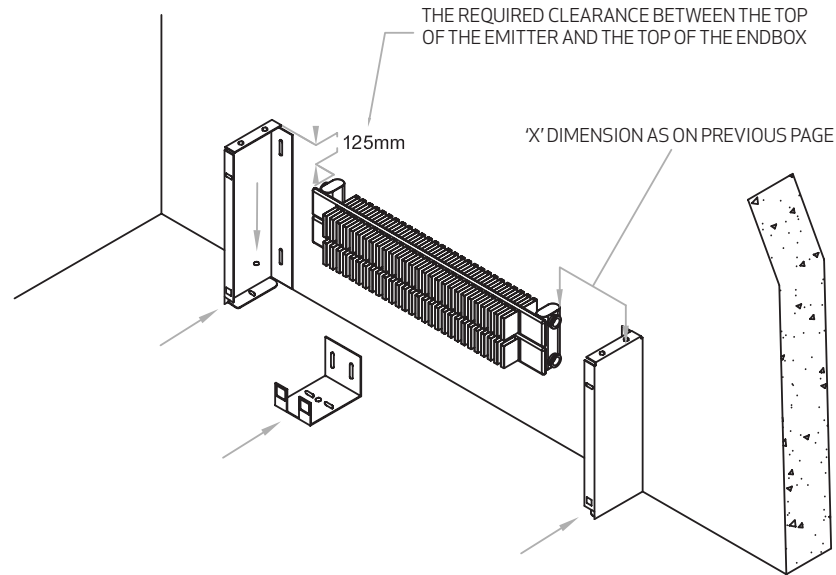

FIG.2

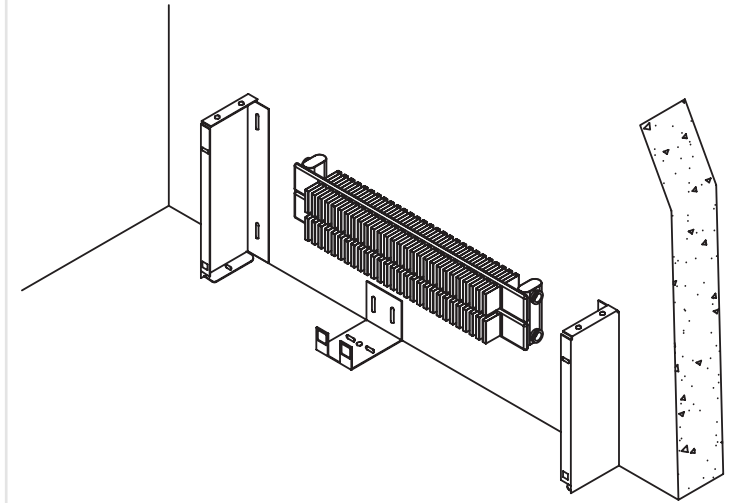

FIG.3

Emitter Height	Case Height
143mm	455mm
215mm	515mm
288mm	585mm
360mm	655mm
433mm	725mm
505mm	795mm
578mm	865mm
650mm	935mm
723mm	1005mm
795mm	1075mm

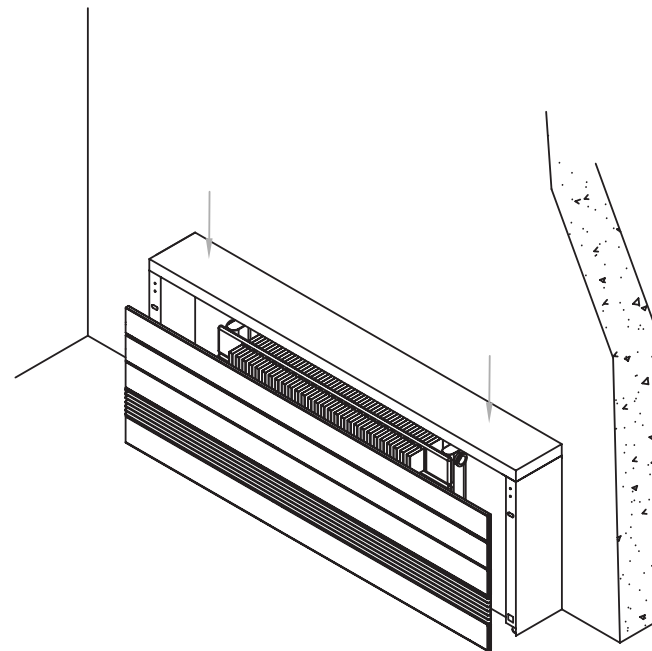
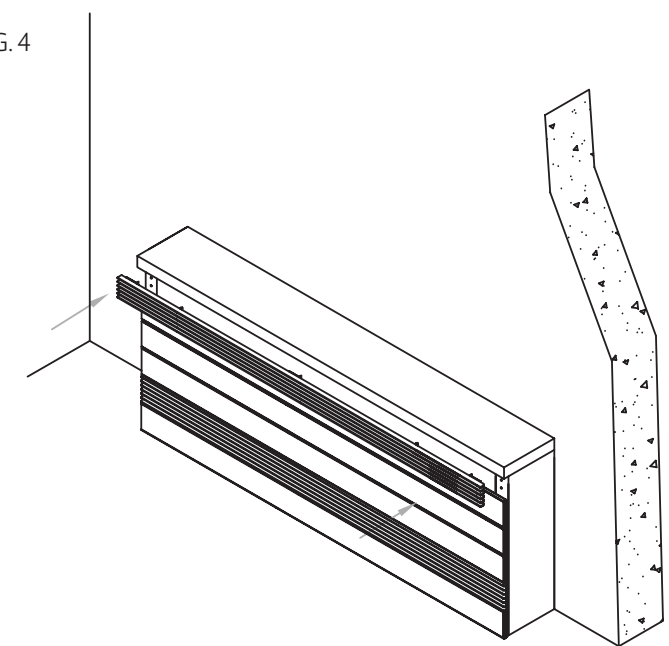

FIG.4



## Information for the installer

Item no.	Parts included	Qty
1	Front Panel	1
2	Endboxes	2
3	Top Front Grille	1
4	Solid Top	1
5	Bracket Kit (Solid Top)	1
6	Bottom Front Grille	1
7	Bottom Plinth	1

## LST Style 28

Floor mounted - suitable for vertical Profile emitters

## EMITTER / LST CASE POSITIONING

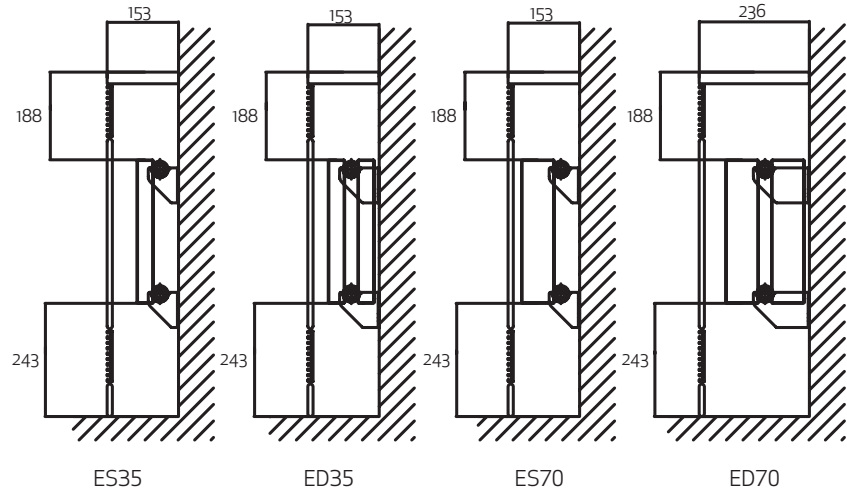

## Important Notes:

- Emitter **ED35** with LST unit shown on exploded view. Installation instructions are provided with emitter.
- Fixings for LST assembly are included in the Bracket Kit (item 5). Fixings to secure LST to the floor are not included.
- Emitter height should be at least 431mm less than overall height of LST.
- For emitters with connection EF/GH, the case width should be emitter width + 140mm.
- For emitters with connection BD/AD, the case width should be emitter width + 280mm.

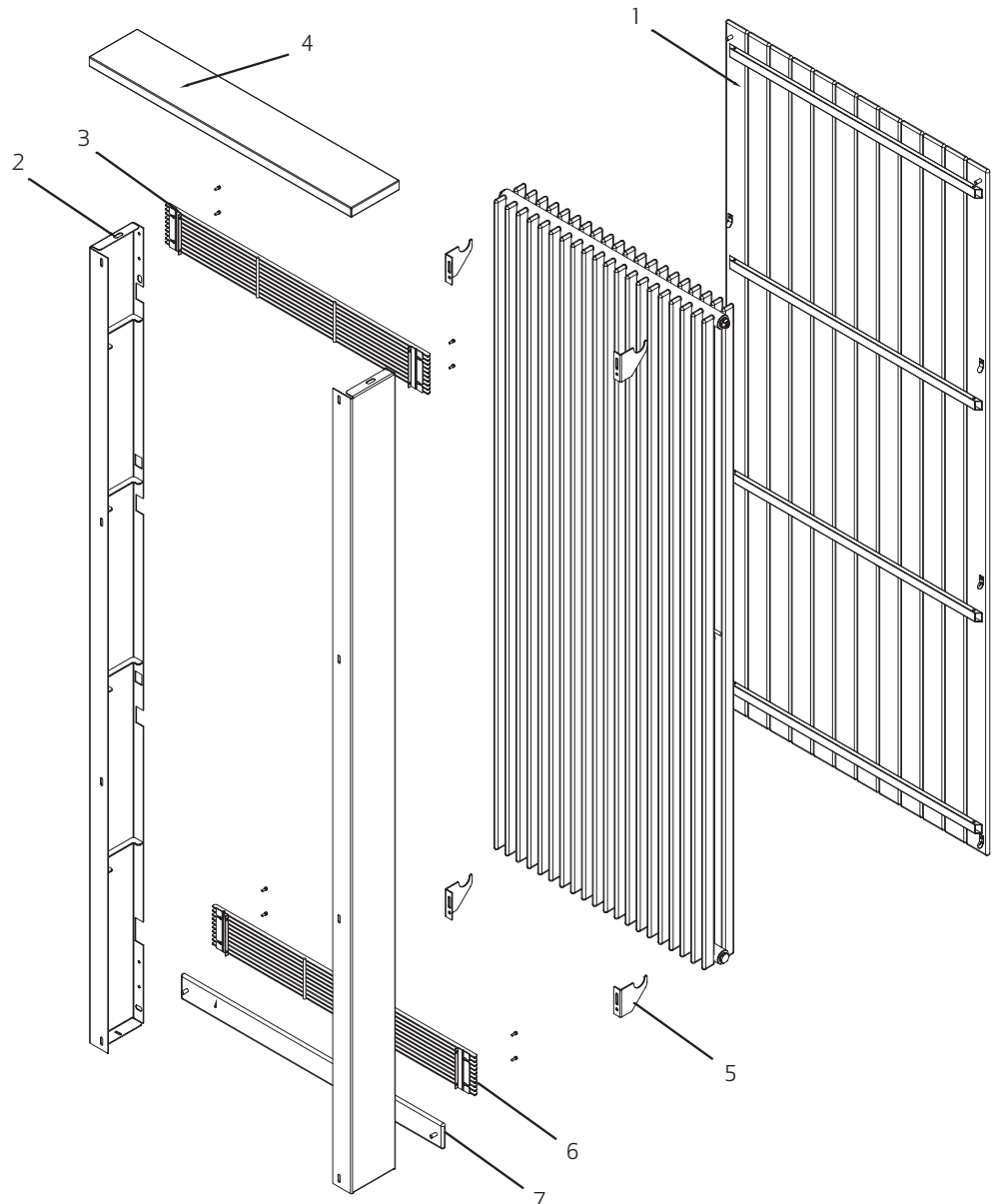

All dimensions are in mm.

**Merriott UK & Ireland**  
 Purmo Group (UK) Ltd,  
 Eastern Avenue,  
 Team Valley, Gateshead,  
 Tyne & Wear, NE11 0PG  
 Tel: 0330 0415 472

sales@merriottuk.com  
 sales@merriott.ie

www.merriottuk.com / www.merriott.ie  
 Follow us on  @merriottuk and 

# LST Style 28

Floor mounted - suitable for vertical Profile emitters

## Installation procedure:

1. Fix endboxes to wall (see FIG. 1).
2. Affix emitter to wall between the endboxes ensuring 243mm remains between the bottom of the radiator and the finished floor (see FIG. 2).
3. Locate tabs on inside of front panel and line up with slots on endbox. Push panel into its upright position and fix using M8 nuts and washers provided. Fit bottom plinth locating studs on plinth and align them to the holes in the endbox (see FIG. 3).

Install bottom front facing grille by inserting hex socket screws through the keyhole plates and into the threaded hole which is located in endbox (see FIG. 4).

4. Affix solid top using bolts provided.
5. Install top front facing grille by inserting M4 hex socket screws through the keyhole plates and into threaded hole which is located in endbox.

