

Information for the installer

LST Style 10

Freestanding - suitable with horizontal Precision emitters

Item no.	Parts included	Qty
1	Front Panel	1
2	Rear Panel	1
3	Endboxes	2
4	Horizontal Top Grille	1
5	Bracket Kit (Grille)	1

Important Notes:

- Fixings for LST assembly are included in the Bracket Kit (item 5). Content will vary depending on the length of the LST.
- Fixings to install LST to the floor are not included.
- Emitter and fixings shown on exploded view. Installation instructions provided with emitter.
- Radiator feet are provided with emitter.

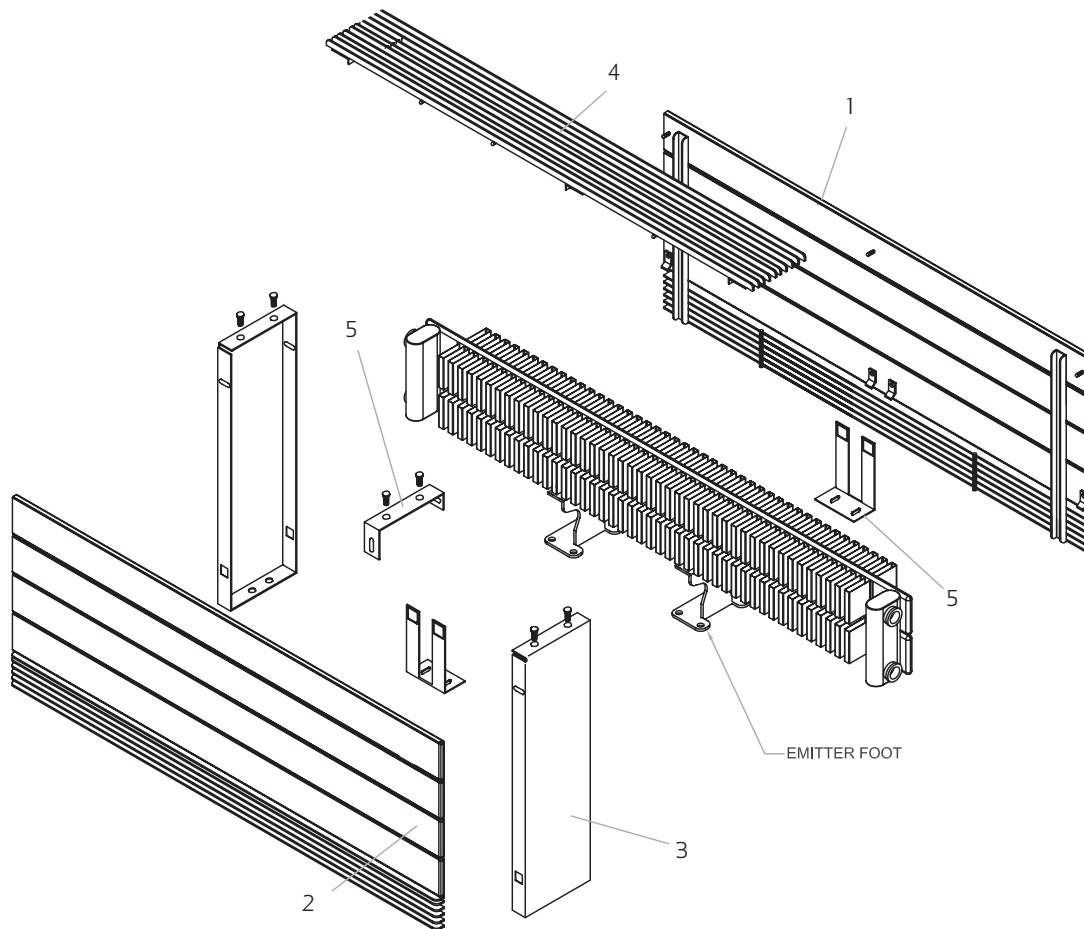

INTERMEDIATE BRACKET PANEL DEPTH & BRACKET TYPE

PANEL LENGTH (mm)	TOP BRACKET SUPPORT	BOTTOM SUPPORT	DIST. A	DIST. B	FIG NO.
	G15 & G25	F10			
0-1000	0	0			
1001-1550	1	2	609	0	1
1501-2150	1	2	909	0	1
2151-2750	1	2	1209	0	1
2751-3000	2	4	909	1809	2

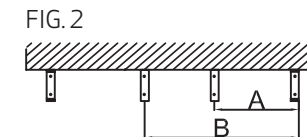
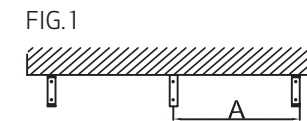

All dimensions are in mm.

Merriott UK & Ireland
 Purmo Group (UK) Ltd,
 Eastern Avenue,
 Team Valley, Gateshead,
 Tyne & Wear, NE11 0PG
 Tel: 0330 0415 472

sales@merriottuk.com
 sales@merriott.ie

www.merriottuk.com / www.merriott.ie
 Follow us on @merriottuk and

EMITTER/LST CASE POSITIONING

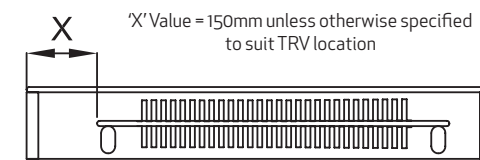
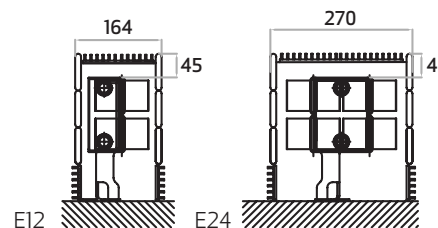

Information for the installer

LST Style 10

Freestanding - suitable with horizontal Precision emitters

Installation Procedure:

1. For TRV cutout positions and LST locations to suit, contact the Merriott sales office.
2. Fix endboxes to floor surface as shown in FIG.1 ensuring that required dimensions are adhered to. The centre of the bottom bracket corresponds to the centre of the intermediate tabs on the front panel.
3. Locate tabs on inside of both panels. Slide into slots provided in endboxes. Push the panel into its upright position and lock in place using M8 nuts and washers (see FIG. 3).
4. Place top grille in position as shown in FIG.4. Lock in place by inserting M4 hex socket screws through the keyhole plates in the grille and into the threaded hole in the endbox.

FIG.1

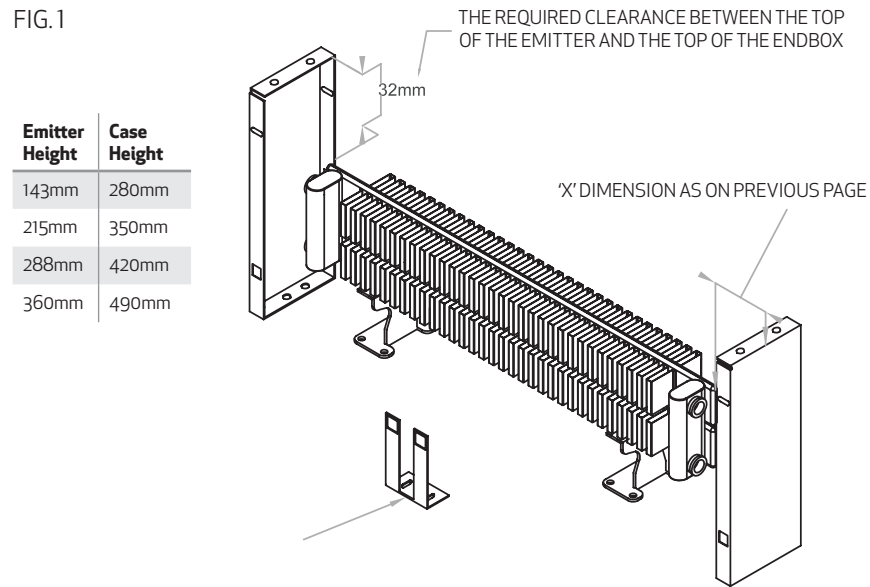

Emitter Height	Case Height
143mm	280mm
215mm	350mm
288mm	420mm
360mm	490mm

FIG.2

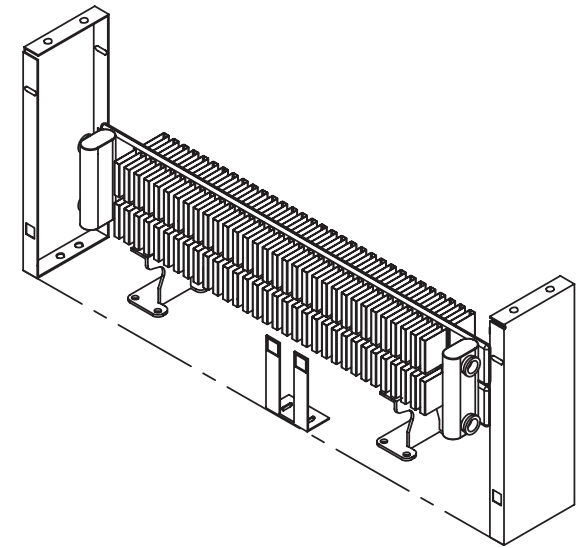

FIG.3

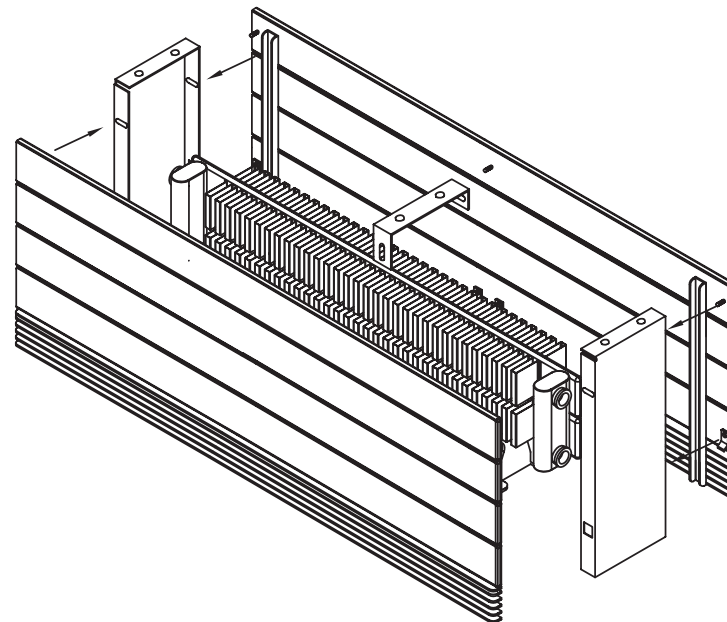

FIG.4

