



LST

INSTALLATION, OPERATING,  
MAINTENANCE & AFTER SALES MANUAL

TEMPLATES INSIDE PLEASE TEAR OUT

Made in the UK by Rettig UK Ltd.  
Please leave this manual with the end user.

## 1.0 General Information

LST radiators are for use on indirect systems only. The system should be designed to follow the recommendations of BS5449 or BS6880, as appropriate, with particular care taken to avoid air entry or water discharge through an open vent. The installation work must be done in accordance with recognised

good practice and precautions taken to avoid contamination, which could lead to corrosion. If a corrosion inhibitor or other water treatment is to be used, the manufacturer's instructions must be strictly followed.

## 2.0 Fixing

- A pair of templates are supplied with the product to ensure the correct positioning of the wall brackets for the emitter and the enclosure (see fig. 1).

**IMPORTANT:** For the correct installation of radiators it is essential that the fixing of the radiator is carried out in such a way that it is suitable for intended use AND predictable misuse. A number of elements need to be taken into consideration including the fixing method used to secure the radiator to the wall, the type and condition of the wall itself, and any additional potential forces or weights that may happen to be applied to the radiator, prior to finalising installation.

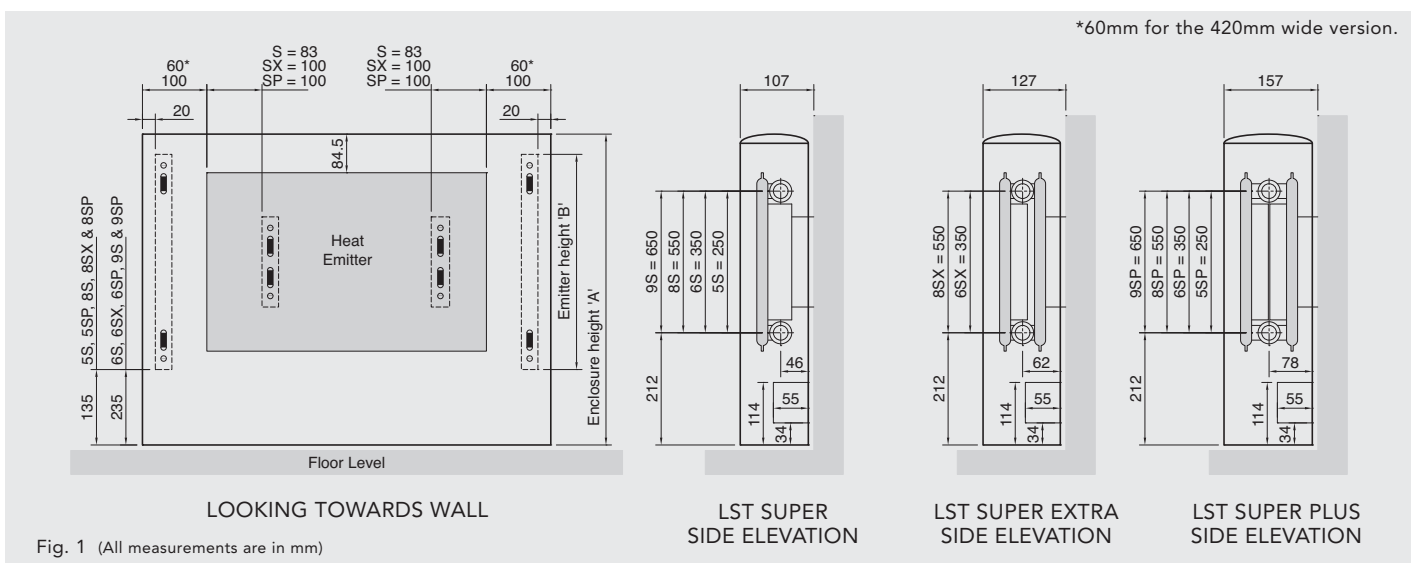

Fig. 1 (All measurements are in mm)

	Enclosure Height - A (mm)			
	572	672	872	972
Emitter Height - B (mm)	300	400	600	700

**IMPORTANT:** It is advisable to leave a further 5mm clearance above any final floor covering to allow for easy fitting and removal.

## 3.0 Water Connections

- If surface mounting pipework is being used, this must be routed and mounted to run within the rectangular cut-outs provided at each end of the enclosure. To remove the cut-out, flex from side to side until the connection is broken. If pipework enters one side only, the other cut-out should be left intact.
- Carry out the plumbing connections in the usual way. Fig 1 shows the clearances between the heat emitter and the enclosure. Ensure that pipework and valves are within these limits to enable correct fitting of the enclosure.

## 4.0 Thermostatic Radiator Valves

LST radiators may be fitted with the following types of thermostatic radiator valves:

Valve Type	Order Code	Connection Options		
		TBSE	TBOE	BOE
Close coupled TRV kit	CCKTC <sup>††</sup>	✓	✓	✓
Remote Adjusting TRV	2TRVADJHEAD2	✓	✓	✓
Remote Sensing TRV	2TRVRSHEAD2			✓
Direct Fit TRV Kit <sup>†</sup>	DIRECTFIT	✓	✓	

<sup>†</sup>Not available for the 420mm wide model.

<sup>††</sup>Order code CCKTC420 = 420 wide model and only available as BOE.

## 5.0 Cleaning and Maintenance - LST Enclosure

- Remove both security screws.
- Lift the LST enclosure out of the wall bracket slots and pull forward.
- To reposition the enclosure, lift the enclosure onto the brackets ensuring correct engagement with the bracket slots. Replace the security screws.
- If the unit is fitted with a Close Coupled or Remote TRV kit then excessive movement of the casing will be restricted by a safety chain.

## 6.0 Full Fitting Instructions

### 1. Position the LST

- Decide upon the final wall position for the LST radiator to be fitted.
- Position the LST enclosure against the wall and mark the position of each end (see fig. 2).

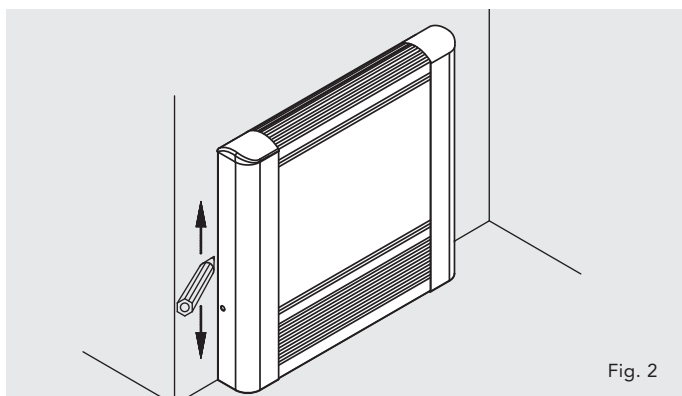

### 3. Fixing bracket positions

- Cut the template as indicated and position each half in the required position, aligning for both height and width.
- Through the template mark and drill the lower bracket fixing points (see fig. 4).

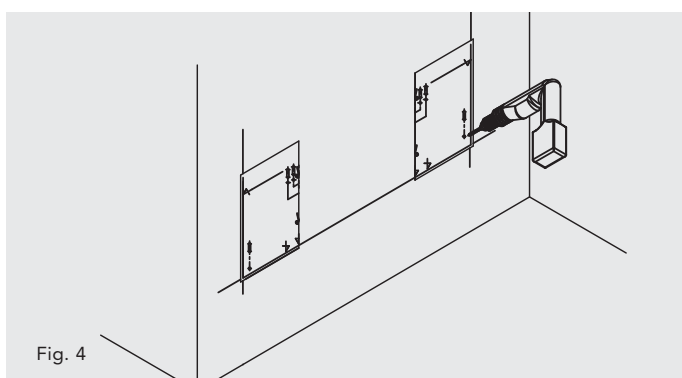

### 5. Fit and plumb the emitter

- Mount the heat emitter onto the wall brackets.
- Carry out the water connections as for standard radiators, ensuring that the pipework and valving will not effect the fitting of the enclosure (see fig. 6).

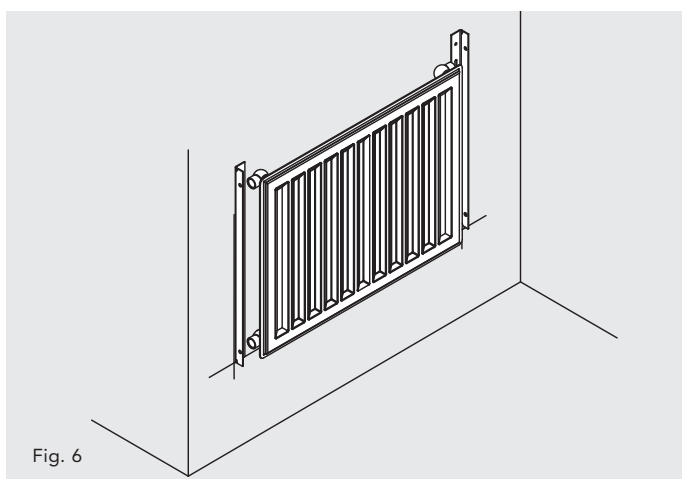

### 2. Distance from floor

- Referring to the supplied template, measure and mark the correct distance from the floor allowing for any floor covering (see fig. 3).

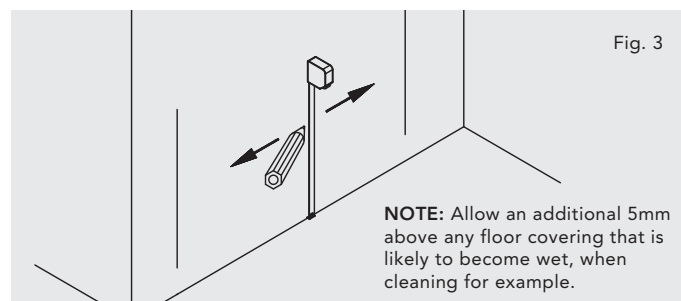

### 4. Fit the fixing brackets

- Plug the wall as necessary and fit the brackets to the wall using the bottom fixing points. Ensure that the brackets are 90° to the floor and mark, drill and plug the upper fixing points.
- Secure the brackets to the wall. Fit the plastic inserts to the emitter brackets and the spire nuts to the enclosure brackets (see fig. 5).

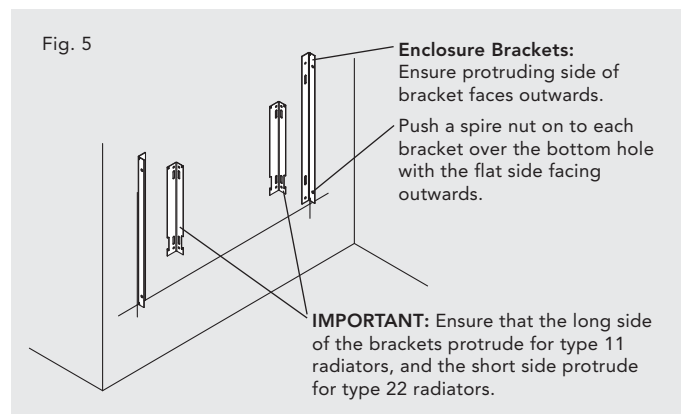

### 6. Fit the enclosure

- Fit the two self adhesive spacers to each back return of the LST enclosure below the pipework knock-outs as shown (see fig. 7).
- Fit the LST enclosure on the wall brackets. Ensure the LST enclosure is located into the mounting slots situated on top of the brackets.
- Secure the LST enclosure to the brackets via the screw holes at each end.

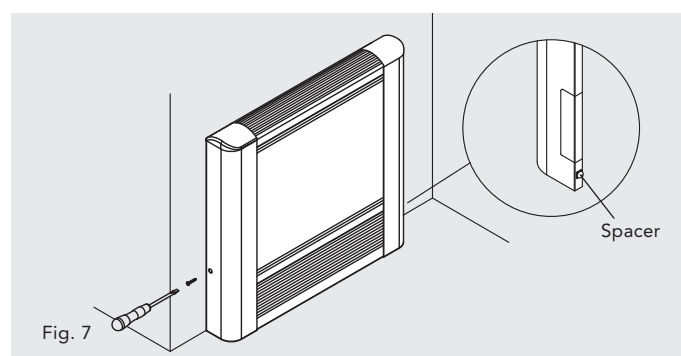

Eastern Avenue, Team Valley, Gateshead, Tyne & Wear NE11 0PG, UK  
T: 0845 402 3434, F: 0191 491 7568, sales@rettigicc.co.uk