

Information for the installer

Optima LST (Wall Mounted)

Item no.	Parts included	Qty
1	40mm long M6 Hex. head setscrews	4
2	40mm long No.8 plastic universal rawl plugs	4
3	M6 washers	4
4	½" BSP air vent	1
5	½" BSP blank	1
6	10mm long M5 pan head screws	2
7	White plastic captive inserts	2

Important Notes:

For indirect or closed circuits only, with a maximum working temperature of 80 C.

General information: The installation and commissioning of the system should comply with BS EN 14336:2004. On completion of the installation, the system should be properly flushed and filled in accordance with the British Code of Practice for the Treatment of Water in Domestic Hot Water Central Heating Systems BS 7593:2006. We strongly recommend the use of a corrosion inhibitor. Failure to comply with these standards may invalidate the manufacturer's warranty.

All dimensions are in mm.

Merriott UK & Ireland
Purmo Group (UK) Ltd,
Eastern Avenue,
Team Valley, Gateshead,
Tyne & Wear, NE11 0PG
Tel: 0330 0415 472

sales@merriottuk.com
sales@merriott.ie

www.merriottuk.com / www.merriott.ie
Follow us on  @merriottuk and 

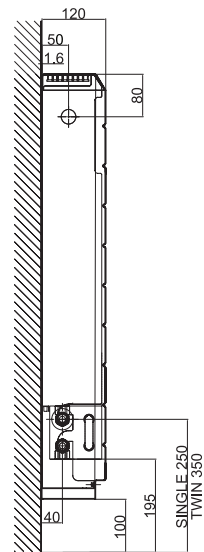

SIDE VIEW TYPE 100

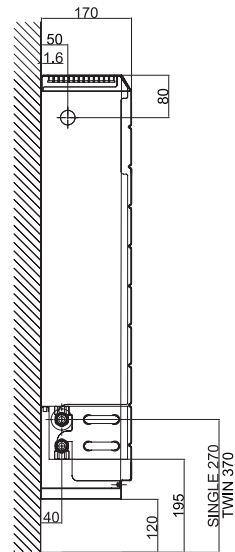

SIDE VIEW TYPE 150

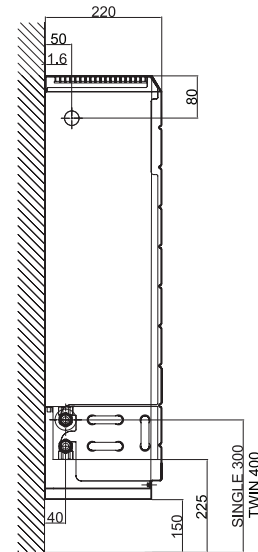

SIDE VIEW TYPE 200

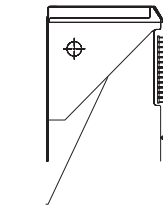
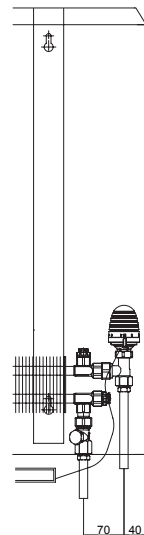
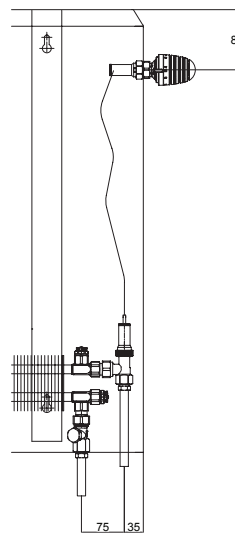
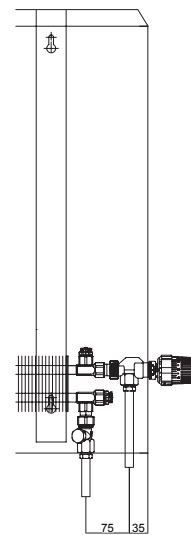
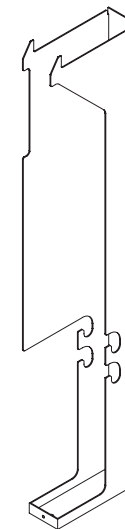
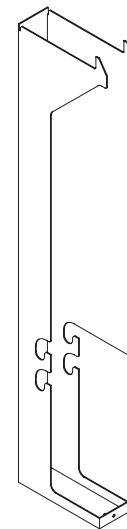
HEAT DEFLECTOR
FITTED TO WFG
MODELS ONLYINTERNAL
CAPILLARY VALVE
(TAMPERPROOF)
NO KNOCKOUTEXTERNAL
CAPILLARY VALVE
TOP KNOCKOUT
Ø27.5MMEXTERNAL
DIRECT VALVE
BOTTOM KNOCKOUT
Ø40MMLEFT HAND
BRACKETRIGHT HAND
BRACKET

Information for the installer

Optima LST (Wall Mounted)

Installation Procedure:

- Allow 125mm wall clearance on both sides of the emitter to allow fitting of the LST casing. If an external TRV is fitted, a further 100mm clearance is required
- Identify which brackets are left hand and right hand (see bracket drawings)
- Position bracket against the wall
- Set bracket vertically level using spirit level
- Mark through the bracket top and bottom hole positions
- Drill and affix suitable wall plug
- Tighten bracket into position using M6 screws and washers supplied
- Attach wall spacer to inside face of both brackets to set second bracket location
- Set second bracket vertically level using spirit level
- Repeat steps 5,6 and 7
- Check all is horizontally level using a spirit level across the wall spacer (see FIG. 1)
- Locate emitter in bracket slots, valve connections to the wall, long side of bracket should sit within the last fin pitch of the emitter on each side (see FIG. 2)
- Install heat deflector through slots in each side of the bracket on WFG models only
- Install TRV valve & lockshield valve (see FIG. 3)
- Knock out corresponding hole in casing to suit TRV arrangement required
- Position casing on brackets by lifting upwards and sideways to clear the TRV valve body
- When in position slide casing back to line up with screw fix positions at the bottom of the casing
- Fix TRV head onto valve body if a direct TRV is fitted (see FIG. 4)
- Secure casing to the brackets using 2 x M5 screws supplied
- Blank off vacant holes with 2 x white plastic captive inserts supplied



Based on external direct Oventrop valve in bottom knock out.

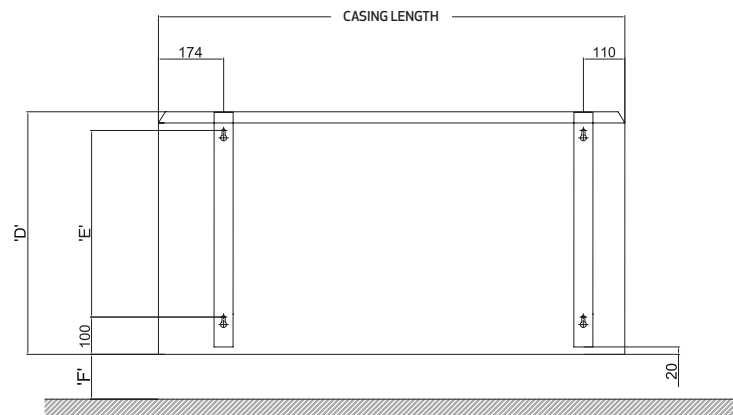

FRONT VIEW - LEFT HAND VALVE POSITION
BRACKET FIXING DETAIL

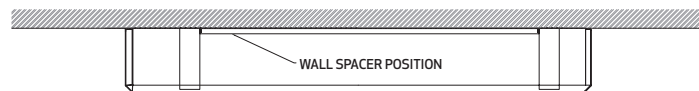

PLAN VIEW - LEFT HAND VALVE POSITION

'D'	'E'
500	350
650	500
800	650

HEIGHTS

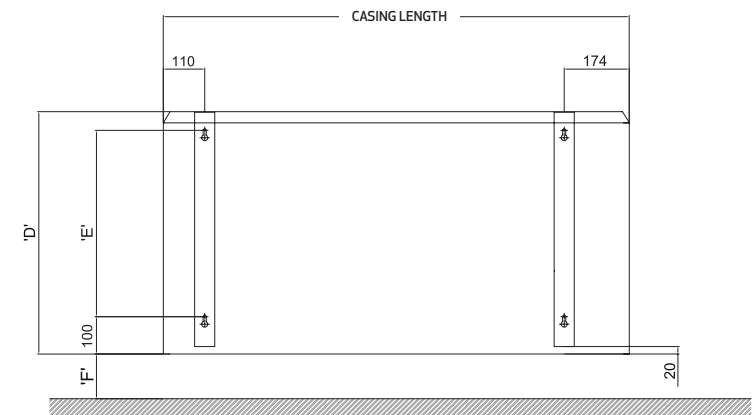

FRONT VIEW - RIGHT HAND VALVE POSITION
BRACKET FIXING DETAIL

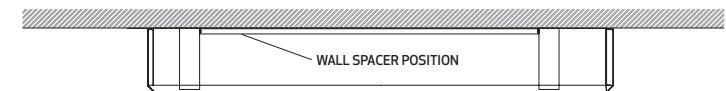

PLAN VIEW - RIGHT HAND VALVE POSITION

DEPTH	'F'
120	100
170	120
220	150

DEPTHS