

Information for the installer

# LST Style 2

Wall mounted - suitable with horizontal Precision emitters

| Item no. | Parts included           | Qty |
|----------|--------------------------|-----|
| 1        | Front Panel              | 1   |
| 2        | Endboxes                 | 2   |
| 3        | Horizontal Top Grille    | 1   |
| 4        | Horizontal Bottom Grille | 1   |
| 5        | Bracket Kit (Grille)     | 1   |

**Important Notes:**

- Fixings for LST assembly are included in the Bracket Kit (item 5). Content will vary depending on the length of the LST.
- Fixings to install LST to the wall are not included.
- Emitter and fixings shown on exploded view. Installation instructions provided with emitter.
- Bottom grille (item 4) measures 20mm LESS than the overall casing length.

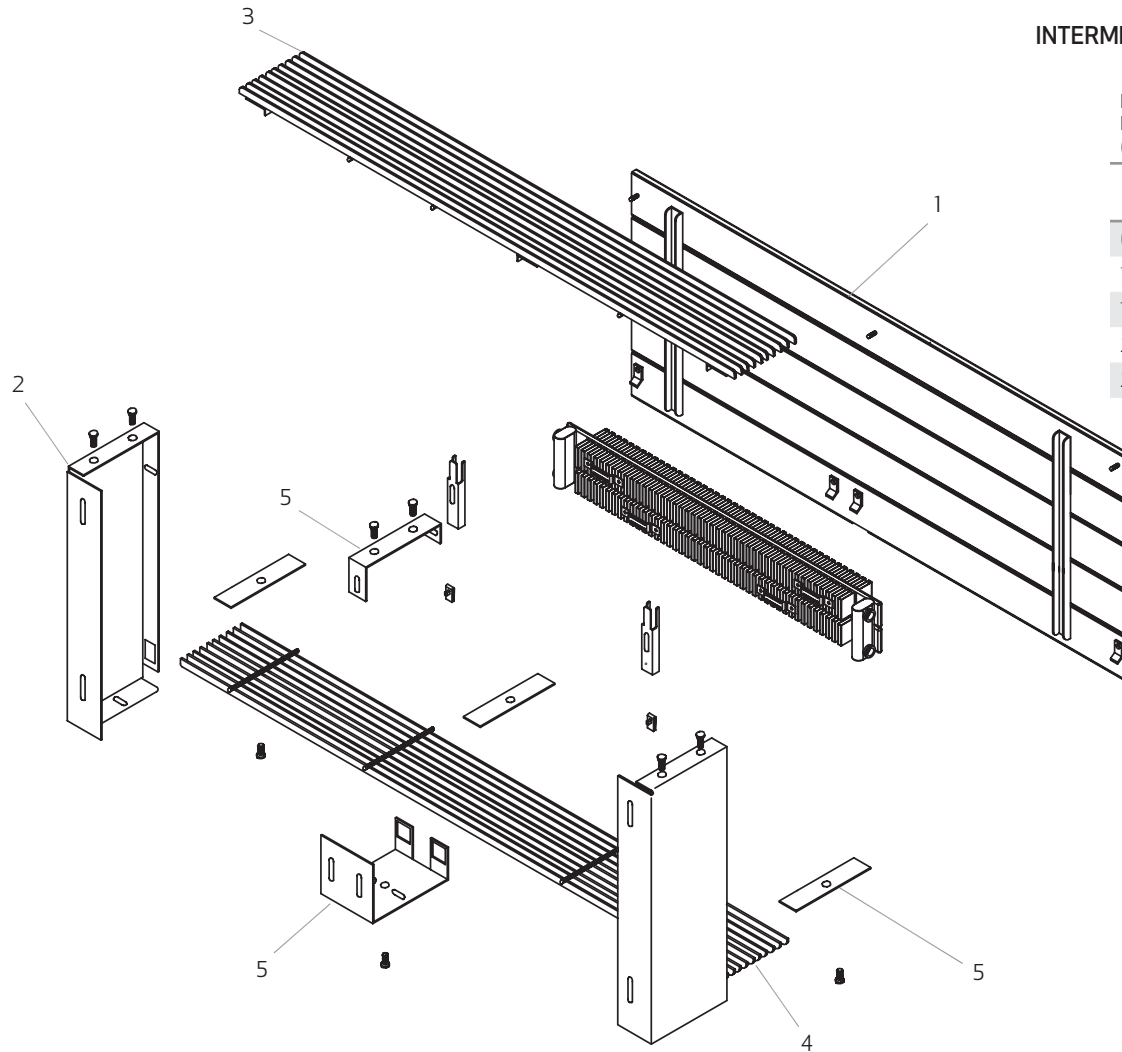

**INTERMEDIATE BRACKET PANEL DEPTH & BRACKET TYPE**

| PANEL LENGTH (mm) | TOP BRACKET SUPPORT       | BOTTOM SUPPORT            | DIST. A | DIST. B | FIG NO. |
|-------------------|---------------------------|---------------------------|---------|---------|---------|
|                   | <b>G10, G15, G17, G25</b> | <b>B10, B15, B17, B25</b> |         |         |         |
| 0-1000            | 0                         | 0                         |         |         |         |
| 1001-1550         | 1                         | 1                         | 609     | 0       | 1       |
| 1501-2150         | 1                         | 1                         | 909     | 0       | 1       |
| 2151-2750         | 1                         | 1                         | 1209    | 0       | 1       |
| 2751-3000         | 2                         | 2                         | 909     | 1809    | 2       |

| PANEL LENGTH | BOTTOM SUPPORT            | DIST. A | DIST. B | FIG |
|--------------|---------------------------|---------|---------|-----|
|              | <b>ST0, ST5, ST7, ST9</b> |         |         |     |
| 0-1000       | 2                         |         |         |     |
| 1001-1550    | 3                         | 609     | 0       | 1   |
| 1501-2150    | 3                         | 909     | 0       | 1   |
| 2151-2750    | 3                         | 1209    | 0       | 1   |
| 2751-3000    | 4                         | 909     | 1809    | 2   |

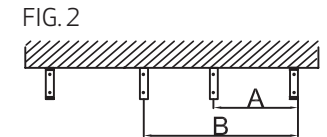
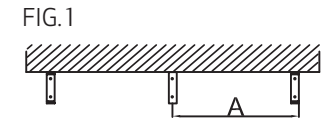

All dimensions are in mm.

**Merriott UK & Ireland**  
 Purmo Group (UK) Ltd,  
 Eastern Avenue,  
 Team Valley, Gateshead,  
 Tyne & Wear, NE11 0PG  
 Tel: 0330 0415 472

sales@merriottuk.com  
 sales@merriott.ie

www.merriottuk.com / www.merriott.ie  
 Follow us on @merriottuk and

**EMITTER/LST CASE POSITIONING**

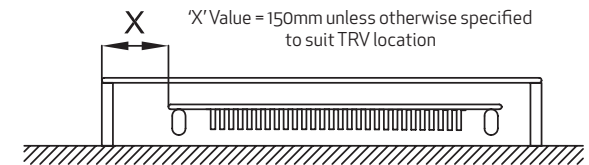
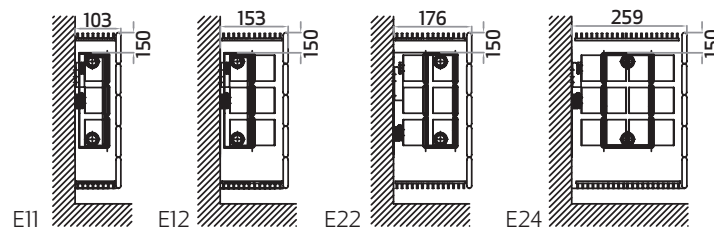

## Information for the installer

# LST Style 2

Wall mounted - suitable with horizontal Precision emitters

## Installation Procedure:

1. For TRV cutout positions and LST locations to suit, contact the Merriott sales office.
2. Fix endboxes to wall surface as shown in FIG. 1 ensuring that required dimensions are adhered to. The centre of the bottom bracket corresponds to the centre of the intermediate tabs on the front panel. The bottom of the bracket should be in line with the bottom of the endboxes.
3. Slide bottom grille onto endboxes and fix using the M4 hex socket screws and grille locking plates provided. (If bottom brackets are required, fix immediately after the bottom grille is fixed, see FIG. 2).
4. Locate tabs on inside of front panel. Slide into slots provided in endboxes. Push the panel into its upright position and lock in place using M8 nuts and washers (see FIG. 3).
5. Place top grille in position as shown in FIG. 4. Lock in place by inserting M4 hex socket screws through the keyhole plates in the grille and into the threaded hole in the endbox.

FIG. 1

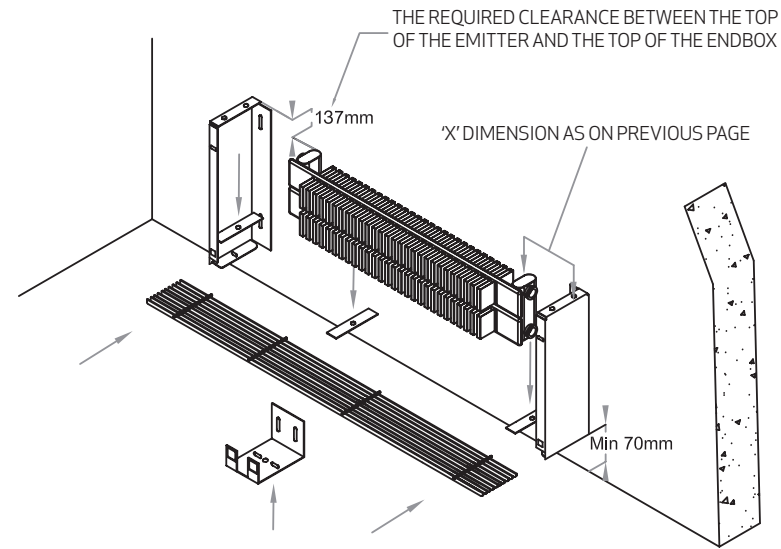

FIG. 2

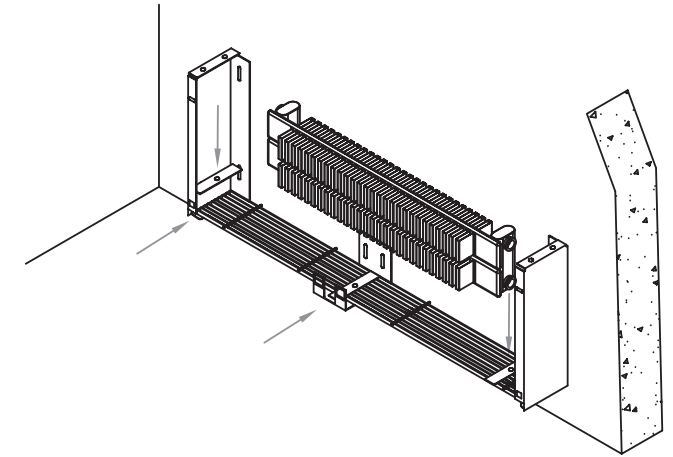

FIG. 3

| Emitter Height | Case Height |
|----------------|-------------|
| 143mm          | 350mm       |
| 215mm          | 420mm       |
| 288mm          | 490mm       |
| 360mm          | 560mm       |
| 433mm          | 630mm       |
| 505mm          | 700mm       |
| 578mm          | 770mm       |
| 650mm          | 840mm       |
| 723mm          | 910mm       |
| 795mm          | 980mm       |

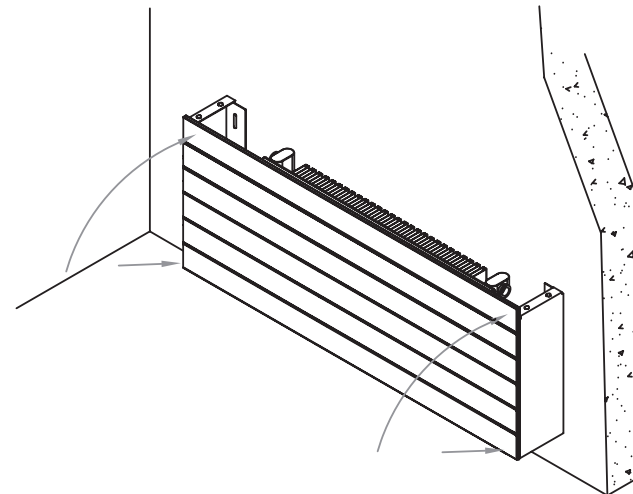
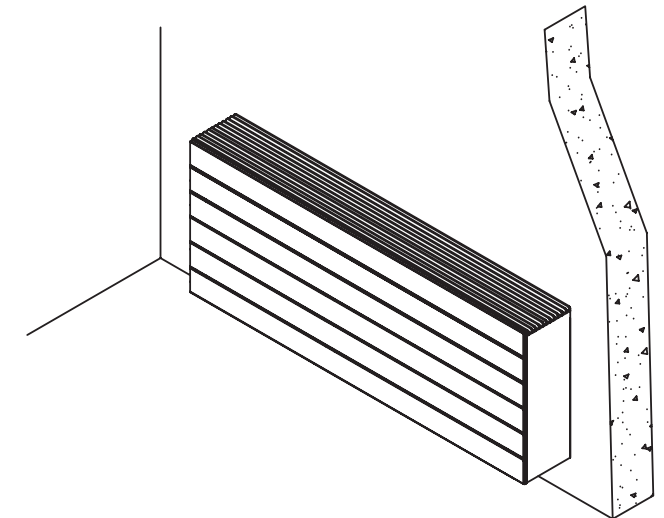

FIG. 4



Information for the installer

# LST Style 6

Wall mounted - suitable with horizontal Precision emitters

| Item no. | Parts included           | Qty |
|----------|--------------------------|-----|
| 1        | Front Panel              | 1   |
| 2        | Endboxes                 | 2   |
| 3        | Solid Top                | 1   |
| 4        | Horizontal Front Grille  | 1   |
| 5        | Horizontal Bottom Grille | 1   |
| 6        | Bracket Kit (Solid Top)  | 1   |

**Important Notes:**

- Fixings for LST assembly are included in the Bracket Kit (item 6). Content will vary depending on the length of the LST.
- Fixings to install LST to the wall are not included.
- Emitter and fixings shown on exploded view. Installation instructions provided with emitter.
- Bottom grille (item 5) measures 20mm LESS than the overall casing length.

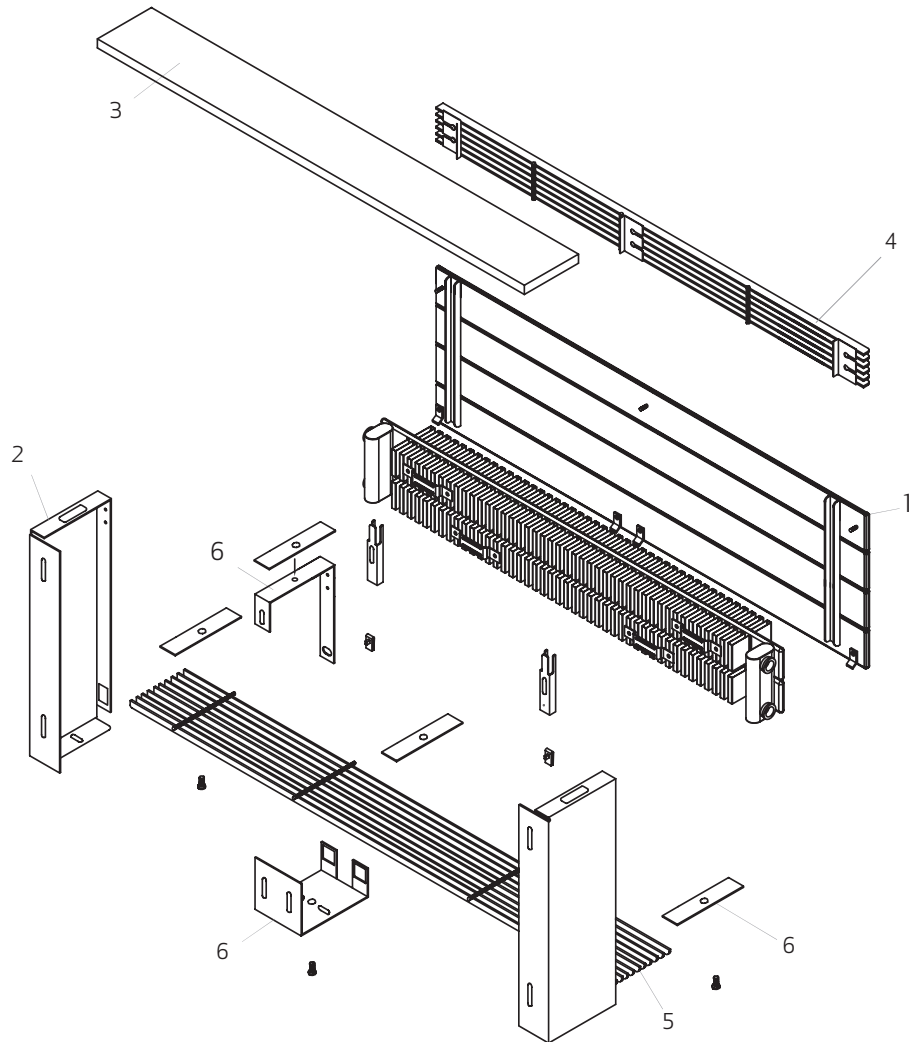

INTERMEDIATE BRACKET PANEL DEPTH & BRACKET TYPE

| PANEL LENGTH (mm) | BOTTOM SUPPORT            | SOLID TOP SUPPORT         | FIXING SUPPORT            | DIST. A | DIST. B | FIG NO. |
|-------------------|---------------------------|---------------------------|---------------------------|---------|---------|---------|
|                   | <b>B10, B15, B17, B25</b> | <b>S10, S15, S17, S25</b> | <b>ST0, ST5, ST7, ST9</b> |         |         |         |
| 0-1000            | 0                         | 0                         | 2                         |         |         |         |
| 1001-1550         | 1                         | 1                         | 4                         | 609     | 0       | 1       |
| 1501-2150         | 1                         | 1                         | 4                         | 909     | 0       | 1       |
| 2151-2750         | 1                         | 1                         | 4                         | 1209    | 0       | 1       |
| 2751-3000         | 2                         | 2                         | 6                         | 909     | 1809    | 2       |

FIG. 1

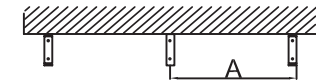
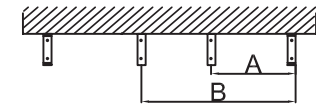

FIG. 2



All dimensions are in mm.

**Merriott UK & Ireland**  
 Purmo Group (UK) Ltd,  
 Eastern Avenue,  
 Team Valley, Gateshead,  
 Tyne & Wear, NE11 0PG  
 Tel: 0330 0415 472

sales@merriottuk.com  
 sales@merriott.ie

www.merriottuk.com / www.merriott.ie  
 Follow us on @merriottuk and

**EMITTER/LST CASE POSITIONING**

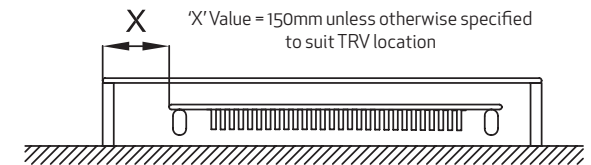
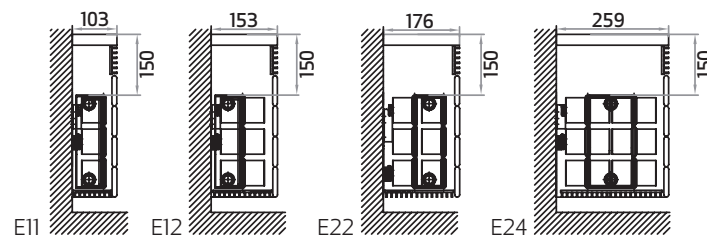

## Information for the installer

# LST Style 6

Wall mounted - suitable with horizontal Precision emitters

## Installation Procedure:

1. For TRV cutout positions and LST locations to suit, contact the Merriott sales office.
2. Fix endboxes to wall surfaces as shown in FIG. 1 ensuring that required dimensions are adhered to.
3. Slide bottom grille onto endboxes and fix using the M4 hex socket screw and grill locking plates provided. If bottom brackets are required, fix immediately after the grille is fixed (see FIG. 2).
4. Locate tabs on inside of front panel. Slide into slots provided in endboxes. Push the panel into its upright position and lock into place using M8 nuts and washers (see FIG. 3).
5. Fix solid top into position with bolts provided.
6. Place top grille in position as shown in FIG. 4. Lock into place by inserting M4 hex socket screws through keyhole plates in the grille and into the threaded hole in the endbox.

FIG. 1

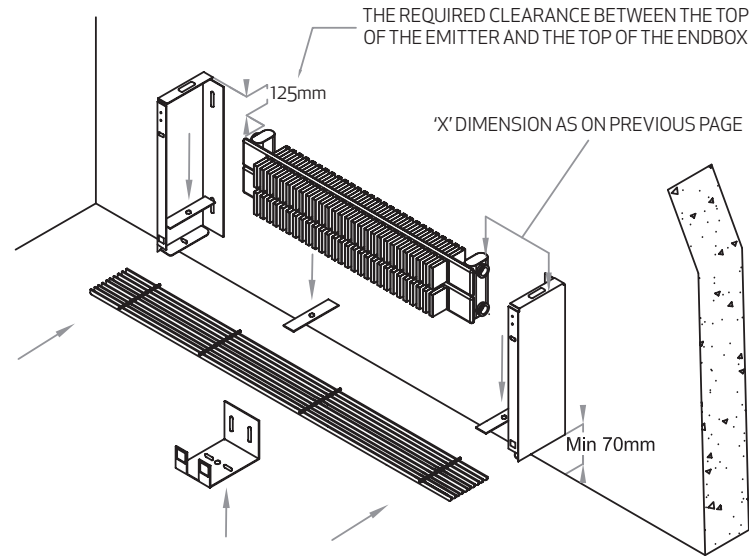

FIG. 2

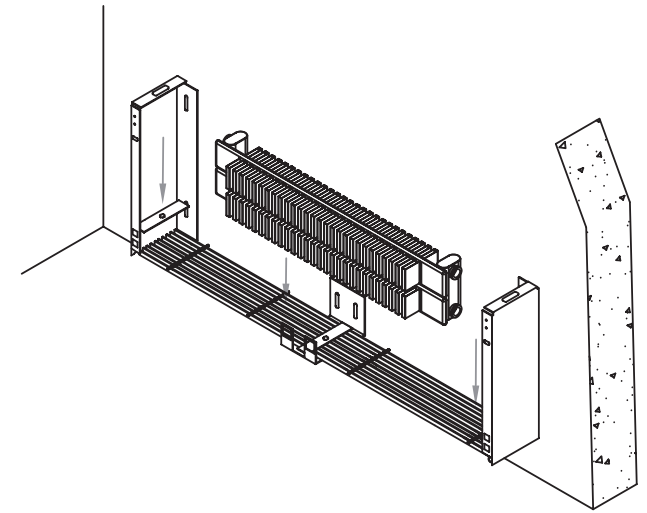

FIG. 3

| Emitter Height | Case Height |
|----------------|-------------|
| 143mm          | 455mm       |
| 215mm          | 515mm       |
| 288mm          | 585mm       |
| 360mm          | 655mm       |
| 433mm          | 725mm       |
| 505mm          | 795mm       |
| 578mm          | 865mm       |
| 650mm          | 935mm       |
| 723mm          | 1005mm      |
| 795mm          | 1075mm      |

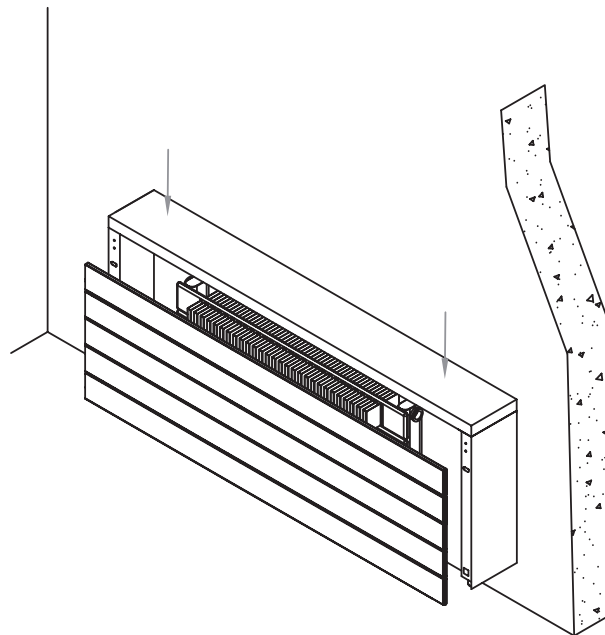
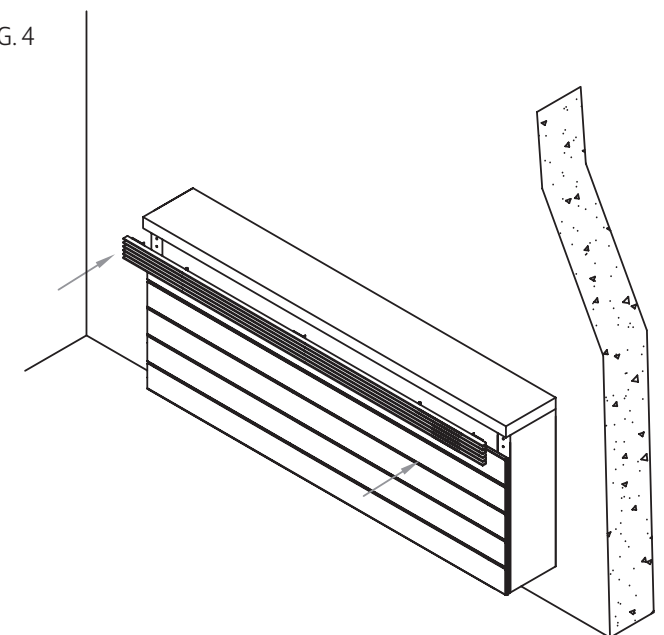

FIG. 4



## Information for the installer

| Item no. | Parts included                     | Qty |
|----------|------------------------------------|-----|
| 1        | Front Panel                        | 1   |
| 2        | Endboxes                           | 2   |
| 3        | Solid Top                          | 1   |
| 4        | Top Front Grille<br>(6 bar grille) | 1   |
| 5        | Bottom Horizontal Grille           | 1   |
| 6        | Bracket Kit (Solid Top)            | 1   |

## LST Style 26

Wall mounted - suitable for vertical Profile emitters

## EMITTER / LST CASE POSITIONING

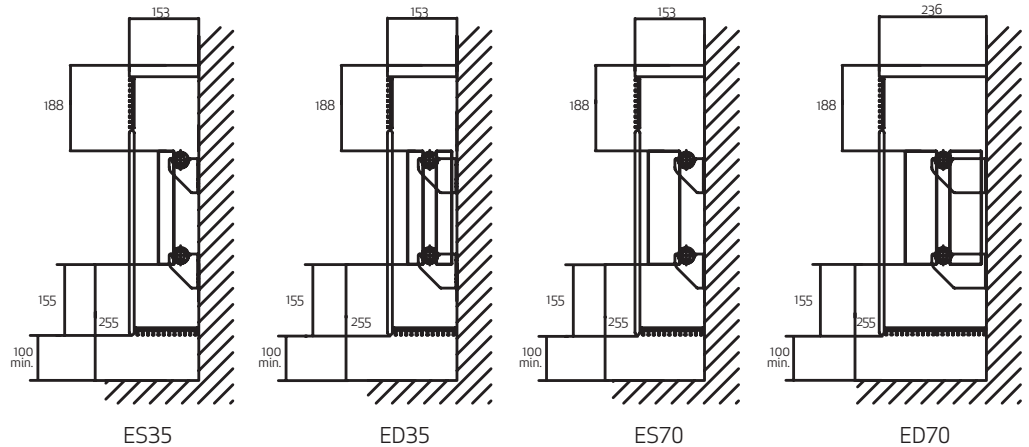

## Important Notes:

- Fixings for LST assembly are included in the Bracket Kit (item 6). Fixings to secure LST to the wall are not included.
- Bottom horizontal grille (item 5) measures 20mm LESS than the length of the overall casing.
- Emitter **ED35** with LST unit shown on exploded view. Installation instructions are provided with emitter.
- Emitter height should be at least 343mm less than the overall height of the LST.
- For emitters with connection EF/ GH, the case width should be emitter width + 140mm.
- For emitters with connection BD/ AD, the case width should be emitter width + 280mm.

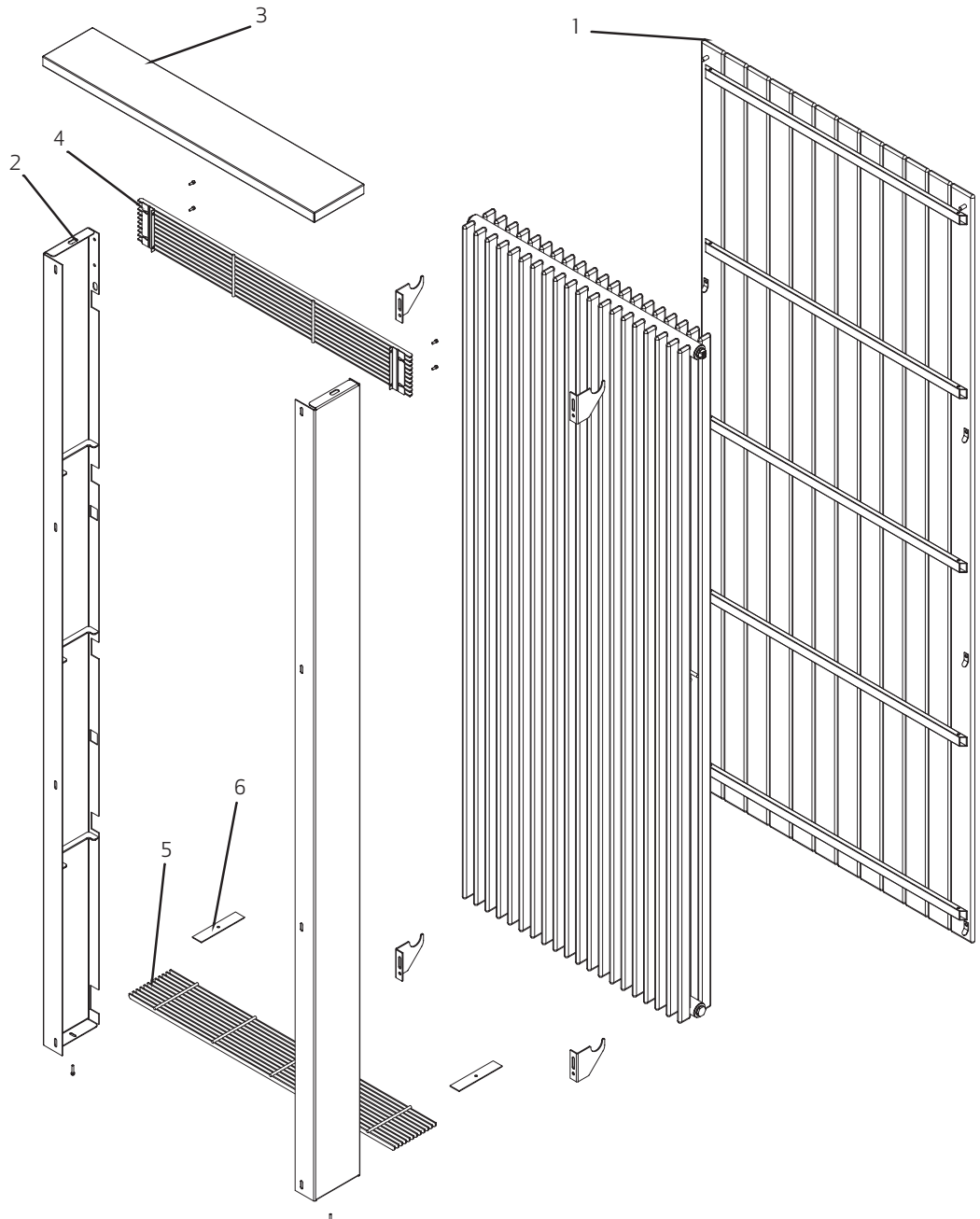

All dimensions are in mm.

**Merriott UK & Ireland**  
 Purmo Group (UK) Ltd,  
 Eastern Avenue,  
 Team Valley, Gateshead,  
 Tyne & Wear, NE11 0PG  
 Tel: 0330 0415 472

sales@merriottuk.com  
 sales@merriott.ie

www.merriottuk.com / www.merriott.ie  
 Follow us on  @merriottuk and 

# LST Style 26

Wall mounted - suitable for vertical Profile emitters

## Installation Procedure:

1. Fix endboxes to the wall 100mm up from the floor (see FIG. 1).
2. Slide bottom grille on to the endboxes and fix using M4 hex socket screws and grille locking plates provided (see FIG. 2).
3. Affix emitter to wall between the endboxes ensuring at least 155 mm between the bottom of the radiator and the bottom grille.
4. Locate tabs on inside of the front panel and line up with slots on endbox. Push panel into its upright position and fix using M8 nuts and washers provided.
5. Affix solid top using bolts provided (see FIG. 3).
6. Install top front facing grille by inserting M4 hex socket screws through the keyhole plates and into a threaded hole which is located in the endbox (see FIG. 4).

